

IRONWOOD SN Island Light



Specifications

| | |
|---------------------------------|---|
| Material Construction: | Formed Steel |
| Lens: | Snow glass |
| Lamp Type & Wattage: | Two 13W GU 24 CFL lamps (2700K) |
| Mounting: | Ceiling mounted |
| Finish: | Satin Nickel (US15) |
| Voltage: | 120V |
| Weight: | 7.85 lbs |
| Companion Fixtures: | Chandeliers, wall mounts, pendants & ceiling mounts |



Dimensions

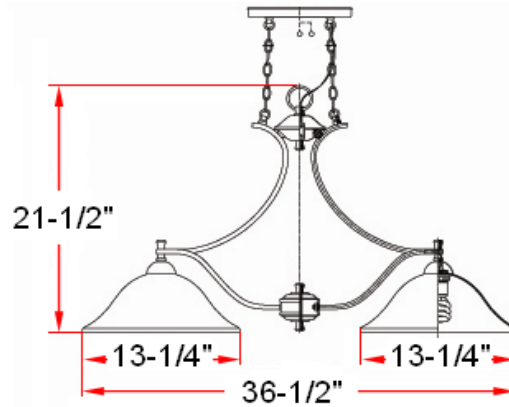

Warranty & Compliances

| | |
|-------------------|--|
| Warranty | 2 Year Limited Warranty |
| UL | UL/cUL listed; Suitable for damp locations |
| ADA | N/A |
| EnergyStar | compliant |



Companion Fixtures

| | | |
|------------------------------|--------|--|
| Island Light | 515569 | |
| 1 LT Wall Sconce | 515619 | |
| 1 LT Wall Mount | 515627 | |
| 2 LT Wall Mount | 515635 | |
| 3 LT Vanity Light | 515692 | |
| 4 LT Vanity Light | 515775 | |
| 2 LT Semi Flush Mount | 515593 | |
| 2 LT Ceiling Mount | 515601 | |
| 3 LT Chandelier | 515536 | |
| 5 LT Chandelier | 515544 | |
| 9 LT Chandelier | 515551 | |
| Pendant | 515577 | |
| Mini Pendant | 515585 | |

Type:

Job:

Order Code:

Approvals:

Design House reserves the right to make changes in materials, specifications & models at any time. Design House also reserves the right to discontinue product without notice or obligation.