

# IRONWOOD SN 9 LT Chandelier



## Specifications

<b>Material Construction:</b>	Formed Steel
<b>Lens:</b>	Snow glass
<b>Lamp Type &amp; Wattage:</b>	Nine 13W GU 24 CFL lamps (2700K)
<b>Mounting:</b>	Ceiling mounted
<b>Finish:</b>	Satin Nickel (US15)
<b>Voltage:</b>	120V
<b>Weight:</b>	20.35 lbs
<b>Companion Fixtures:</b>	Chandeliers, wall mounts, pendants & ceiling mounts



## Dimensions

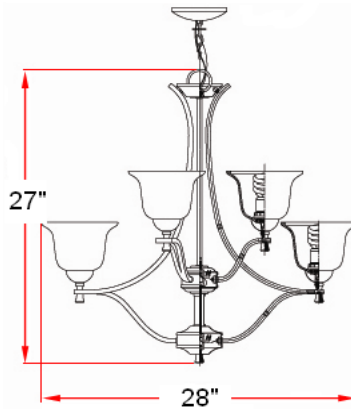

## Warranty & Compliances

<b>Warranty</b>	2 Year Limited Warranty
<b>UL</b>	UL/cUL listed; Suitable for damp locations
<b>ADA</b>	N/A
<b>EnergyStar</b>	compliant



## Companion Fixtures

<b>9 LT Chandelier</b>	515551	
<b>1 LT Wall Sconce</b>	515619	
<b>1 LT Wall Mount</b>	515627	
<b>2 LT Wall Mount</b>	515635	
<b>3 LT Vanity Light</b>	515692	
<b>4 LT Vanity Light</b>	515775	
<b>2 LT Semi Flush Mount</b>	515593	
<b>2 LT Ceiling Mount</b>	515601	
<b>3 LT Chandelier</b>	515536	
<b>5 LT Chandelier</b>	515544	
<b>Island Light</b>	515569	
<b>Pendant</b>	515577	
<b>Mini Pendant</b>	515585	

**Type:**

**Job:**

**Order Code:**

**Approvals:**

Design House reserves the right to make changes in materials, specifications & models at any time. Design House also reserves the right to discontinue product without notice or obligation.